

DURAMAX TRIO

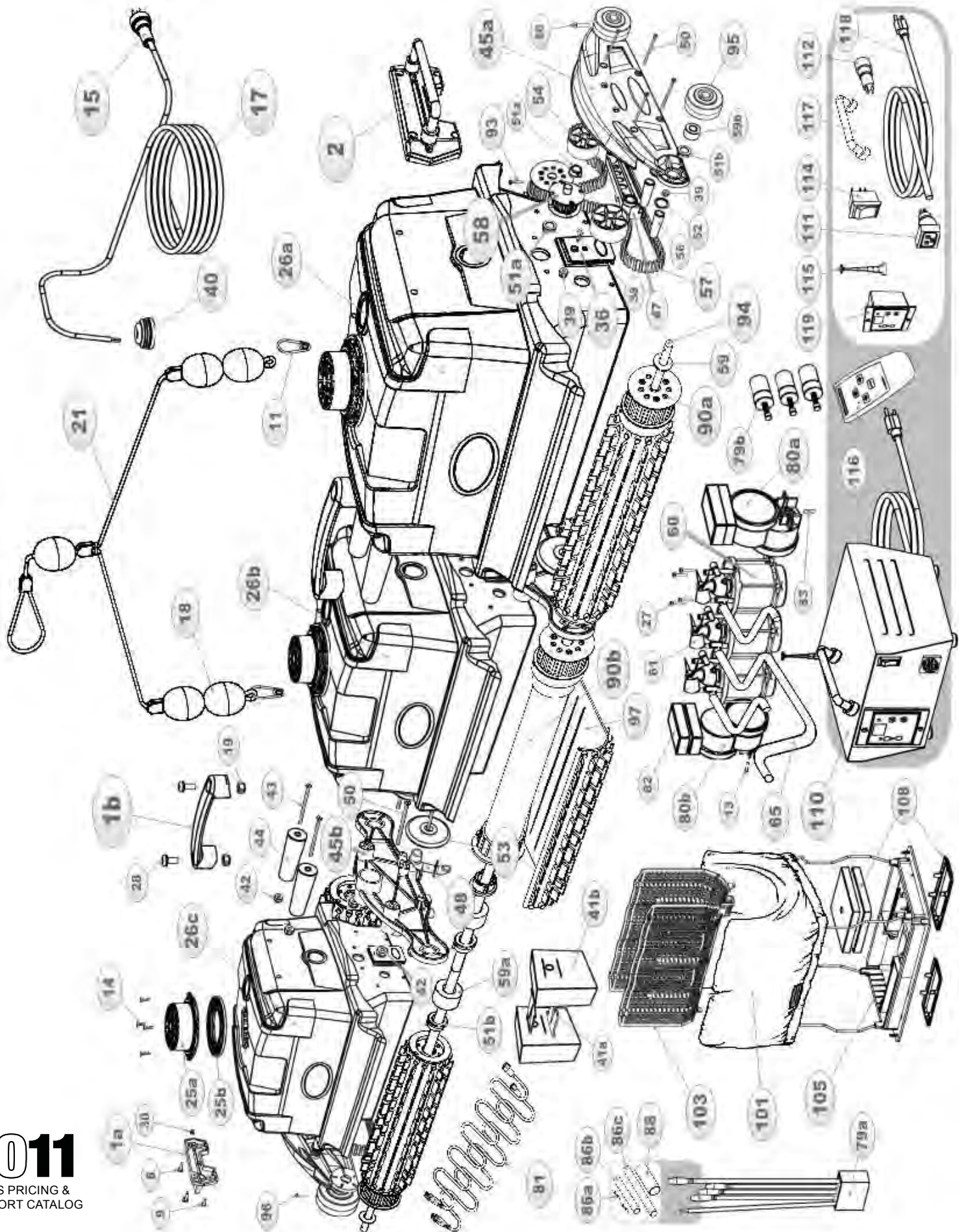

ITEM #	PART #	ITEM NAME (Description) - Quantity per DuraMAX Trio	LIST PRICE	UNITS
	1a	A7022 HANDLE ASSEMBLY (Metal, Hinged Side Handle attached to Bracket) - 2 per machine	\$00.00	EA
	1b	S7010 TOP HANDLE (Black, Plastic, For top center of machine) - 2 per machine	\$00.00	EA
	2	SK2039BL SK HANDLE BRACKET, OVAL, BLUE;(EA/1/1)	\$00.00	EA
	8	2304 SCREW (10-32, 3/4", Pan Head, For fastening the Handle Bracket to the Body Assembly) - 8 per machine	\$0.00	EA
	9	2304 SCREW (10-32, 3/4", Phil Pan Head, fastens the Handle Bracket to the Body Assembly) - 4 per machine	\$0.00	EA
	11	11006 HOOK (St. Steel, Snap-Hook, Eyelet for Pin, fastens Rope Assembly to Handles) - 2 per machine	\$0.00	EA
	13	2700 SCREW (#8, 11/16", Phil Pan-Flat Head, Use to fasten Drive Motors) - 4 per machine	\$0.00	EA
	14	2260 SCREW (#6, 7/16", Phil Pan-Flat Head, Use to fasten Outlet Tops) - 12 per machine	\$0.00	EA
	15	1638 PLUG (9-Pin, Female, 9-Wire) - 1 per machine	\$00.00	EA
	17	A164150 CABLE ASSEMBLY (4-Wire, 150 Ft., 9-Pin Plug Included, 0.5" Diameter, 2-14AWG & 2-16AWG Wires) - 1 per machine	\$000.00	EA
	18	1602 FLOAT BALL (Large, fasten two on ends of Rope near Handle and one to Cable at max pool depth) - 5 per machine	\$0.00	EA
	19	2717 NUT (5/16-18, For Handle Top) - 4 per machine	\$0.00	EA
	21	A8324 ROPE ASSEMBLY (Blue & White, Nylon, Attaches to unit to assist lifting) - 1 per machine	\$00.00	EA
	25a	2230B1 OUTLET TOP (Blue) - 3 per machine	\$00.00	EA
	25b	2250BL2 OUTLET BOTTOM (Blue) - 3 per machine	\$00.00	EA
	26a	S2005WBMLM BODY ASSEMBLY (MASTER Motor side, White, with Lock Tabs, Pump hole, Inserts) - 1 per machine	\$000.00	EA
	26b	S2005WBLC BODY ASSEMBLY (CENTER body, White, with Lock Tabs, Pump hole, Inserts) - 1 per machine	\$000.00	EA
	26c	S2005WBLS BODY ASSEMBLY (SLAVE Motor side, White, with Lock Tabs, Pump hole, Inserts) - 1 per machine	\$000.00	EA
	27	2251 SCREW (8-18 x 3/4", Phil Small Head, to fasten Pump to Body) - 12 per machine	\$0.00	EA
	28	2716 SCREW (Stainless Steel, to fasten the Top Handle to the Body) - 4 per machine	\$0.00	EA
	30	3402 NUT, S/S, HEX LOCK M5; (EA/8/8)	\$0.00	EA
	36	9204N LOCK TAB, PLASTIC, NATURAL; (EA/2/2)	\$0.00	EA
	38	2303 SCREW (18-8, 8/32" x 1/2", Phil Bev Head, Use to fasten the Lock-Tabs to the Body Assembly) - 6 per machine	\$0.00	EA
	39	7133 LOCK-NUT (18-8, 8/32", Nylon Insert, Hex, for Lock-Tabs, Sideplates and Middle Sideplate) - 22 per machine	\$0.00	EA
	40	1628 GROMMET (Rubber, .375"ID x 1.375"OD, Use around Cable Assembly on Body) - 1 per machine	\$0.00	EA
	41a	3477 BRACKET (Plastic, fastens Float to inside of Body Assembly) - 4 per machine	\$0.00	EA
	41b	3109 FLOAT (Grey, Foam, requires Bracket, fastened to inside of Body Assembly) - 4 per machine	\$0.00	EA
	42	8305 NUT (10-32, Nylon Insert, fastens Body Assemblies together at the top of unit) - 4 per machine	\$0.00	EA
	43	8323 SCREW (10-32, 3/4", fastens Body Assemblies together at the top of unit) - 2 per machine	\$0.00	EA
	44	2905 SPACER (2.5 inch, 3/4", Black, Plastic, Top Spacer for between Bodies) - 4 per machine	\$00.00	EA
	45a	S2038BL SIDEPLATE ASSEMBLY (New-style design, Blue) - 2 per machine	\$00.00	EA
	45b	3388BL MIDDLE SIDEPLATE (Blue plate for between Body Assemblies) - 2 per machine	\$00.00	EA
	47	S3387 SPACER BRACKET (Supports Drive Belt, For inside Sideplates) - 2 per machine	\$0.00	EA
	48	3386WT JET NOZZLE TUBE (Plastic, White, For Middle Sideplate) - 2 per machine	\$0.00	EA
	50	2711 SCREW (8-32 x 2.75", Screws for Sideplate, for middle Sideplate on bottom) - 16 per machine	\$0.00	EA
	51a	2600 BUSHING (White, Plastic, For Pulley Assembly) - 2 per machine	\$0.00	EA
	51b	2600BKT2 BUSHING (Black, Molybdenum polymer, for both ends of each Wheeltube and Pulley) - 12 per machine	\$0.00	EA
	52	2606 WASHER (White, Delrin plastic, .75" x .032", for sideplate legs) - 4 per machine	\$0.00	EA
	53	3393BK SMALL WHEEL (Black, 2 under Middle Sideplate) - 2 per machine	\$0.00	EA
	54	3508 TENSION ROLLER (Black, Plastic, Supports the Drive Belt) - 4 per machine	\$00.00	EA
	56	3626 BUSHING (Stainless Steel, for Sideplate legs) - 4 per machine	\$0.00	EA
	57	SK3310 SK BELT SET COMMERCIAL DRIVE BELTS (2) WITH TENSION ROLLERS (4), (EA/1/1)	\$000.00	EA
	58	SK3624 PULLEY ASSEMBLY (Includes Flange Washers) - 2 per machine	\$00.00	EA
	59a	2607 WASHER (Delrin, Spacer, .515"OD x 1"ID x .125Lg., use 3 between Wheeltube and Middle Sideplate) - 12 per machine	\$0.00	EA
	59b	11087 SPACER (Delrin, 1"OD x .5"ID x .59"Lg., for outside of Sideplate on Axle) - 4 per machine	\$0.00	EA
	60	SA69010 PUMP MOTOR (With Propeller and Red Impeller, 2-Pin Fem to Capacitor, 2-Pin Male to Junction) - 3 per machine, formerly A601503, installation kit included	\$000.00	EA
	61	4400 PROPELLER - 3 per machine	\$00.00	EA
	65	300096 TUBING (Clear PVC, 5/16"ID x 1/2"OD) - Use to divert water from the Impeller to the Jet Nozzles - 2 feet per machine	\$0.00	EA
	79a	A2302 JUNCTION BOX ASSEMBLY (4-Wire cord to Cable, 2-Pin Fem to Pumps, 4-Pin Fem to Master Drive) - 1 per machine	\$000.00	EA
	79b	6012 RUNNING CAPACITOR (Blue, Cylinder, 2-Pin Male Connect to Pump Motor) - 3 per machine	\$00.00	EA
	80a	SA89021 DRIVE MOTOR (MASTER, Air Sensor, 4-Pin Male Connect to Junction, 4-Pin Female to Slave Drive) - 1 per machine, formerly A8559, installation kit included	\$000.00	EA
	80b	SA89022 DRIVE MOTOR (SLAVE, 4-Pin Male Connect to Master Drive Motor) - 1 per machine, formerly A8561, installation kit included	\$000.00	EA
	81	6120 JUNCTION EXTENSION (4-Pin Female to Male to connect Master Drive Motor to Slave Drive Motor) - 2 per machine	\$00.00	EA
	82	3101 UNDER MOTOR FLOAT (For under Drive Motors) - 4 per machine	\$0.00	EA
	83	4613 SPIRAL PIN (3/4", solid St. Steel, for end of Drive Motor shaft, use small drop of Lock-Tite) - 1 per machine	\$0.00	EA
	88	1625 SHRINK TUBE (3/4" Wide, Black, Thick Rubber, For sealing electrical connections wider than 1/4")	\$00.00	EA
	90a	S38228 WHEEL TUBE ASSEMBLY (for Side Body, requires Axle) - 4 per machine	\$00.00	EA
	90b	S38229 WHEEL TUBE ASSEMBLY (for Center Body, requires Axle) - 2 per machine	\$00.00	EA
	92	3603 WASHER (Nylon, Flat, Use for end of Wheeltubes inside of Sideplate) - 4 per machine	\$0.00	EA
	93	2714 SCREW (10-32, 2.5", Pan Head, Screw for Outer Wheel Tube hubs) - 4 per machine	\$0.00	EA
	94	342627 AXLE, S/S, .500 "D x 47.875 "L, DMX 2011; (EA/1/1)	\$00.00	EA
	95	S700021 WHEEL (Grey, 2.5 inch, with hole for screw, Use on end of the Axles, outside Sideplate) - 4 per machine	\$00.00	EA
	95	2691 WHEEL, 2.75" 00 X 1/2 "ID" BLACK	\$00.00	EA
	96	2718 SCREW (#8, 2", Fillister head, fastend Grey Wheel to Axle) - 4 per machine	\$0.00	EA
	97	SK3016BL SK BRUSH, RUBBER EZ, BLUE, 12", PINS INC, 2x2 PK;(EA/1/1)	\$00.00	EA
	101	8111 FILTER BAG (Small, Fine Filter Bag) - 2 per machine	\$00.00	EA
	101	8112 FILTER BAG (Optional, Small, Mesh Filter Bag) - 2 per machine	\$00.00	EA
	103	5310 FILTER SCREEN (Blue, Folding Cage, no Attachment Strings needed) - 3 per machine	\$00.00	EA
	105	A9600BL BOTTOM LID ASSEMBLY (Blue, W-wire frame, with bottom black wheels) - 3 per machine	\$00.00	EA
	108	SPK9600 FLOAT KIT (Optional, includes floats and Bottom Lid Extension Brackets) - 3 sets per machine	\$00.00	EA
	110	A7168 POWER SUPPLY (9-Pin, GFCI Circuit Breaker) - 1 per machine	\$000.00	EA
	111	SK7140 SK SOCKET, 9 PIN, MALE, W/HDW; (EA/1/1)	\$00.00	EA
	112	7005 FUSE HOLDER (Standard, Push & Turn style) - 1 on Power Supply	\$0.00	EA
	7008	FUSE (8.0 Amp, 250 Volt, Slow-Blow) - 1 on Power Supply	\$0.00	EA
	114	7107 WIDE LIGHTED SWITCH (Very Wide, 1 1/2" x 1", Red, 3-Wire) - 1 on Power Supply	\$0.00	EA
	115	7024 ANTENNA (Telescopic, with Hardware) - 1 on Power Supply	\$00.00	EA
	A220216	RECEIVER (Radio, 4-Way, Responds to 220120C Transmitter) - 1 on Power Supply	\$000.00	EA
	116	220120C TRANSMITTER (Radio RC, Yellow/ Blue buttons/ Red light, for A220216 Receiver, battery incl.) - 1 per machine	\$00.00	EA
	117	7064 HANDLE (Stainless Steel, with Hardware) - 1 on Power Supply	\$00.00	EA
	118	7102 CORD FOR POWER SUPPLY (3-Wire, Green, Black, and White) - 1 on Power Supply	\$00.00	EA

Parts marked with this symbol should be installed by the Factory or an Authorized Service Center. Otherwise a Warranty Waiver must accompany any order for these parts.